

PROPRIETARY - THIS DOCUMENT CONTAINS CONFIDENTIAL, PROPRIETARY INFORMATION THAT IS FOX PROPERTY. DO NOT DISCLOSE TO OR DUPLICATE FOR OTHERS EXCEPT AS AUTHORIZED BY FOX.

REVISIONS				
ZONE	REV	DESCRIPTION	DATE	APPROVED
	A	PRODUCTION RELEASE	9/12/14	MD/VH

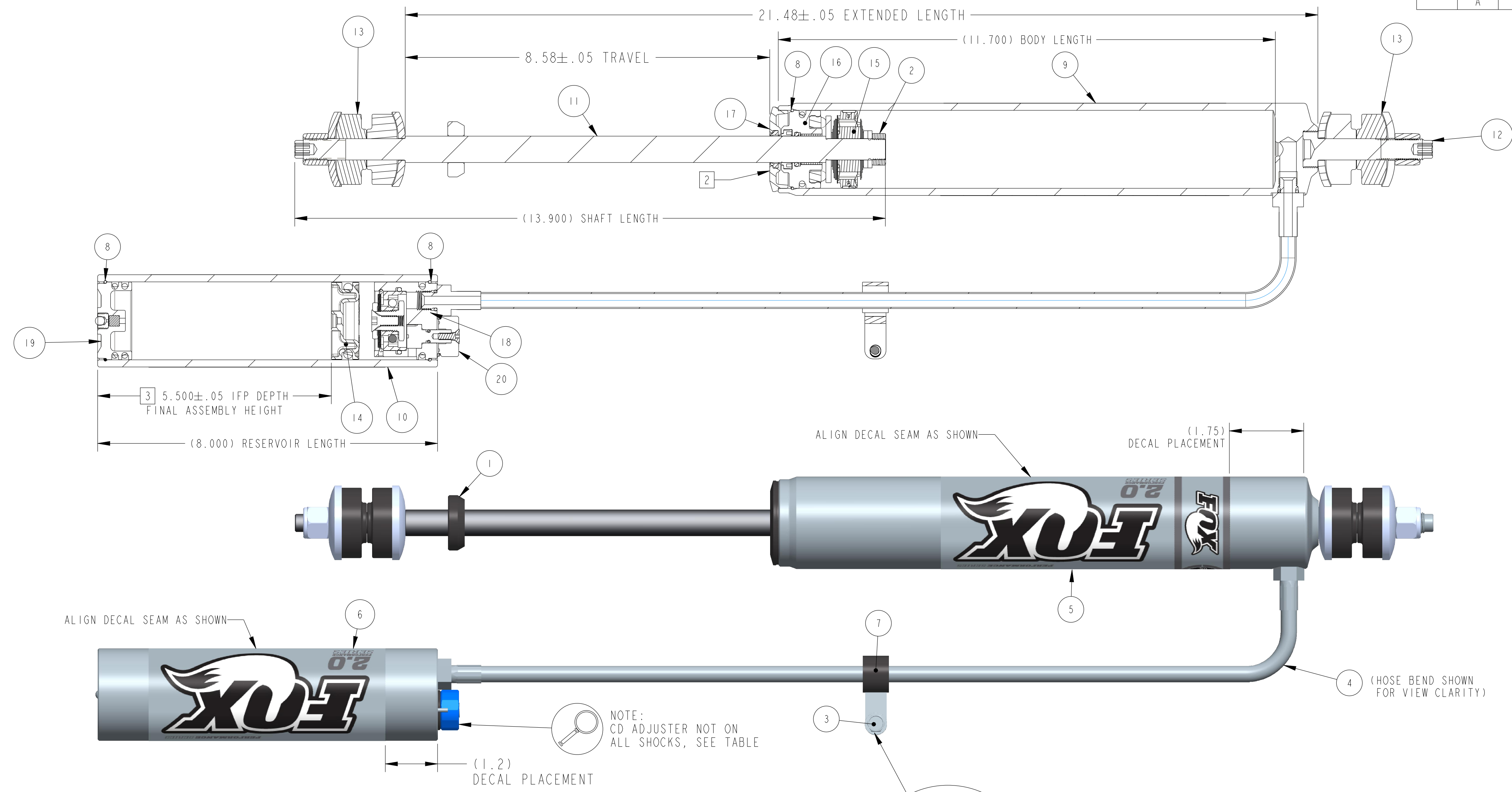

NOTE:  
HARDWARE KIT 803-02-061  
TO BE INCLUDED IN BOX

NOTE:  
P/N 026-00-011 AND 018-01-049  
TO BE INCLUDED IN BOX

ITEM	PART NUMBER	DESCRIPTION	QTY
1	008-01-000	Bumper: B/O [Ø 0.620 Shaft, 0.453 TLG] nitrile	1
2	018-00-034	Fastener, Standard: Nut, Lock, Reversible [1/2-20 THD X 0.323 TLG] Steel, Zinc	1
3	018-01-049	Fastener, Standard Screw [1/4-14 X 1.00 TLG] Steel, Zinc, Self-Drilling	1
4	023-05-038-B	Hose: [-5, 7/16-20 O'Ring Boss X 7/16-20 O'Ring Boss, 20.000 TLG] Off Road only	1
5	024-04-031	Decal: O/R, [6.8" X 6.8"] Fox 2.0 Performance Series Body Decal	1
6	024-04-039	Decal: O/R, [6.8" X 5.57"] Fox 2.0 Performance Series Body Decal, Remote Res	1
7	026-00-011	Mounting Hardware: Loop Clamp, Rubber Wrapped [ 3/8" ID, 17/64" Mounting Hole]	1
8	038-01-005	Retaining Ring: Wire [0.062 CS X 1.850 ID] 17-7 SS	3
9	207-45-117-X	Body: (T) [Ø 1.834 Bore, Ø 11.700 Bore Depth, 12.700 TLG ] Post Mount, R/R	1
10	227-44-080-X	Reservoir: (T) [Ø 1.834 Bore, Ø 2.170 OD, 8.000 TLG ] Al 6061	1
11	229-68-113	Shaft: (T) [0.620 OD, 11.300 LG, 13.900 TLG Steel, Chrome, Solid, 1.400" Post Le	1
12	241-02-072	Fastener, Custom: Stud [1/2-20 Thread, 3.050 TLG]	1
13	803-00-701	Kit: Mounting Hardware, Ø.500 Stem Mount, 3.050 TLG, Stud	2
14	805-00-049	Piston Assembly: Floating [Ø 1.834 Bore, 0.650 TLG] w/ Standard O-ring	1
15	807-20-009	Valving Assembly: 2.0 Performance Series, Tuned Combination 009	1
16	812-07-027	Bearing Assembly: [Ø 1.834 Bore, Ø 0.620 Shaft, 0.995 TLG]	1
17	812-11-019	Bearing Assembly: Bearing Cap Assembly [Ø 1.834 Bore, Ø 0.620 Shaft] Black Ano,	1
18	813-00-061	Reservoir End Cap Assembly: [Ø 1.834 Bore, 7/16-20 ] Black Ano	1
19	813-00-079	Reservoir End Cap Assembly: [Ø 1.834 Bore] Pellet Port, Black Ano, Dbl Oring	1
20	815-00-036	Damping Adjust Assembly: Compression Damping Housing [Ø 1.834 Bore]	1

- NOTES:
- APPLICATION REFERENCE: LAND ROVER DEFENDER (83-95) & DISCOVERY 1 (94-98) FRONT - 0-1" LIFT.
  - BEARING STAMPED WITH FOX PART NUMBER AND WORK ORDER NUMBER.
  - IFP DEPTH DIMENSION IS AFTER FINAL ASSEMBLY. SEE DOCUMENT 610-05-112 FOR IFP PRE SEAL-HEAD INSTALLATION HEIGHT
  - NITROGEN CHARGE PRESSURE 200 ±10 PSI.
  - SEE REFERENCE DRAWING 610-02-299 FOR SHAFT ASSEMBLY INSTRUCTIONS.
  - SEE REFERENCE DRAWING 610-02-306 FOR REMOTE BODY AND IFP ASSEMBLY INSTRUCTIONS.
  - SEE REFERENCE DRAWING 610-05-060-XX FOR MOUNT CONFIGURATION INSTRUCTIONS.

PART NO.	CD ADJUSTER
985-24-122	NO
985-26-122	YES

UNLESS OTHERWISE SPECIFIED, DIMENSIONS ARE IN: INCHES [MM]	PER ASME Y14.5M 1994	<b>FOX Factory, Inc.</b> 130 Hangar Way, Watsonville, CA 95076 USA Ph 831-768-1100 Fax 831-768-9312
	APPROVALS	
TOLERANCES ARE:	DWN. BY M DESROCHER	28-Aug-14
DECIMALS .XX [ .X ] ± .01 [ 0.25 ]	CHK. BY	
ANGLES ± 1°	ENG. B SMITH	28-Aug-14
THIRD ANGLE PROJECTION	MFG.	
DO NOT SCALE DRAWING	ADD.	
TITLE 83-95 Defender & 94-98 Discovery 1 Land Rover, Front PS, 2.0, R/R, 8.6", 0-1" Lift		SIZE DWG. NO. <b>985-24-122</b>
PLOT SCALE 0.90:1		SHEET 1 OF 1